

| | | | | | | |
|--|-------|-------------|------------------------|-------------|-----|------|
| UNIVERSAL ANALYZERS INC. | | E 01/28/10 | Revised For Modularity | | MW | DA |
| 1701 South SutröTerrace Carson City, Nevada 89706 USA | | REV | DATE | DESCRIPTION | DWN | APVD |
| MODEL 1060 SAMPLE COOLER ARRANGEMENT | | REVISIONS | | | | |
| DATE | SCALE | SIZE | SHEET | | | |
| 12/19/1997 | N/A | D | 1 OF 2 | | | |
| DRAWN BY | FOR | DRAWING NO. | | | | |
| APVD BY | N/A | P0247 | | | | |
| PART NO. | FOR | | | | | |
| NOT ISSUED | N/A | | | | | |

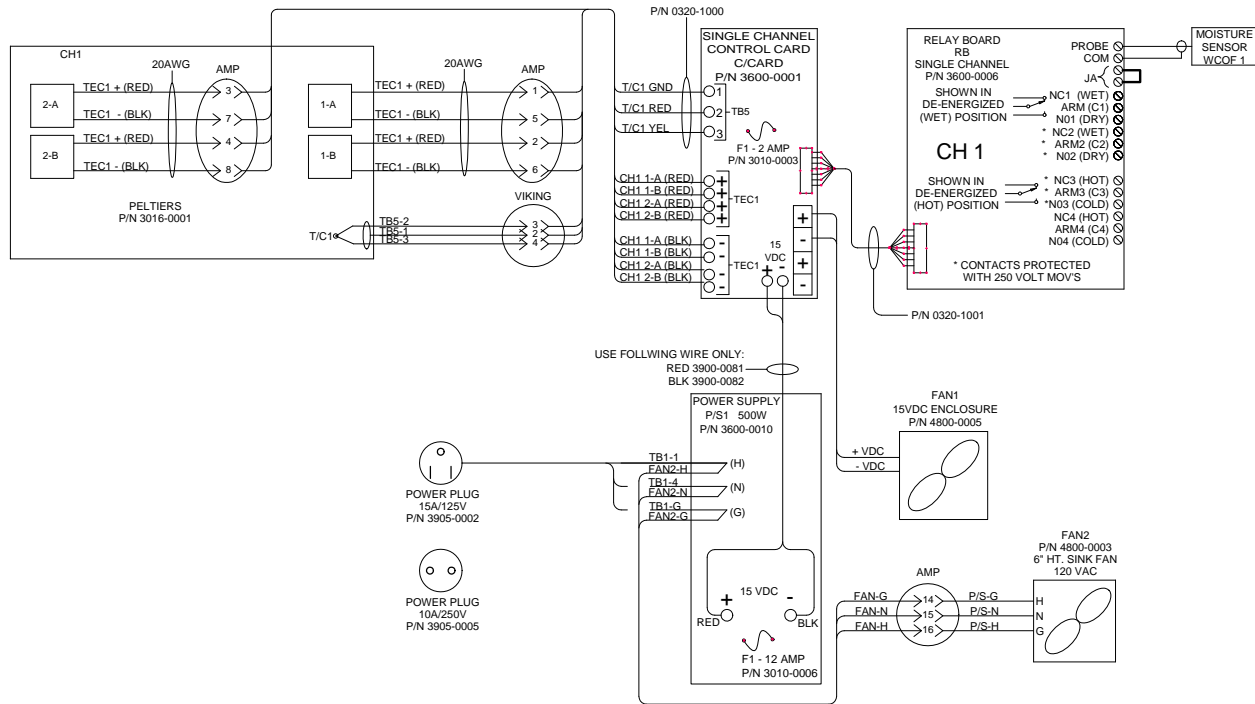

CONDUIT AND WIRING NOTES

1. ELECTRICAL CLASSIFICATION: INSIDE - GENERAL PURPOSE SYSTEM IS CONFIGURED AT THE FACTORY FOR REQUIRED VOLTAGE. CONTACT FACTORY FOR VOLTAGE CHANGE REQUIREMENTS.

2. AC WIRING SHALL BE INDIVIDUAL CONDUCTORS OF STRANDED TINNED COPPER WITH 300V, TYPE TFE INSULATION. MINIMUM WIRE SIZE SHALL BE 18 AWG UNLESS OTHERWISE SPECIFIED. COLOR CODE SHALL BE AS FOLLOWS:

115V - HOT - BLACK 230V - HOT - BROWN
 NEUTRAL - WHITE NEUTRAL - BLUE
 GROUND - GREEN GROUND - GREEN

3. DC WIRING SHALL BE INDIVIDUAL CONDUCTORS OF STRANDED TINNED COPPER WITH 300V, TYPE TFE INSULATION. MINIMUM WIRE SIZE SHALL BE 22 AWG UNLESS OTHERWISE SPECIFIED. COLOR CODE SHALL BE AS FOLLOWS, UNLESS OTHERWISE SPECIFIED:

115V +V RED 230V +V RED
 -V BLUE -V BLACK

RELAY BOARD NOTES

4. USER CONNECTIONS TO MOISTURE SENSOR RELAY ENERGIZED WHEN SENSOR IS DRY (DRY LED ON). RATING: 1/10HP 120VAC 5A 240VAC/32VDC RESISTIVE.

5. USER CONNECTIONS TO 'AT TEMPERATURE' RELAY ENERGIZED WHEN BELOW SET TEMPERATURE (COOL LED ON). RATING: 1/10HP 120VAC 5A 240VAC/32VDC RESISTIVE.

 FIELD TO WIRE

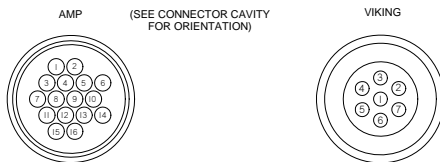

| | | | | | |
|---|-----|-------------|------------------------|-------------|----------|
| UNIVERSAL ANALYZERS INC. | | E 01/28/10 | Revised For Modularity | MW | DA |
| 1701 South Sutro Terrace Carson City, Nevada 89706 USA | | REV | DATE | DESCRIPTION | DWN/APVD |
| MODEL 1060 SAMPLE COOLER WIRING SCHEMATIC | | | | | |
| PART NO. | FOR | DATE | SCALE | SIZE | SHEET |
| NOT ISSUED | N/A | 12/19/1997 | NTS | D | 2 OF 2 |
| DRAWN BY E. Musselman | | DRAWING NO. | | P0247 | |
| APVD BY T. Barben | | | | | |